

Engine Timing Kit - for Honda 1.5 Petrol & 1.6 Diesel

The 8130 has been developed to allow the user to lock the 1.5L petrol and 1.6L diesel engines found across the Honda car range in their "timed" position, so the camshaft drive chain can be safely removed and replaced or the engine timing checked.

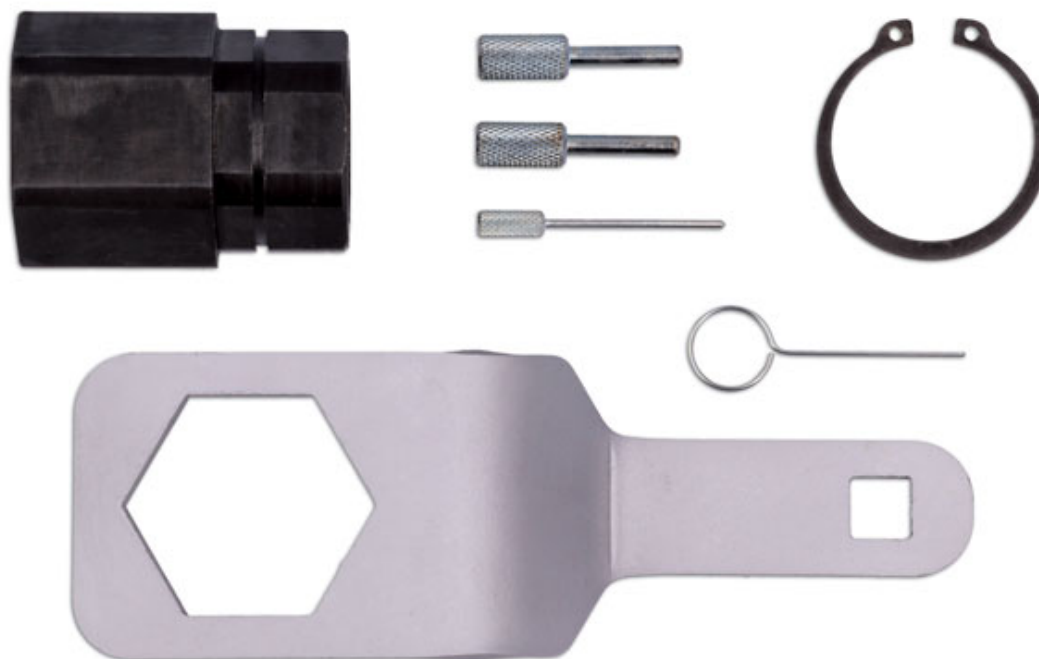

Additional Information

- Honda applications include: Civic (from 2012), CR-V (from 2013), HR-V (from 2015), Jazz (from 2014).
- Honda 1.5L petrol engine codes: 1.5lt L15B4, L15B7, L15BA, L15BB, L15B.
- Honda 1.6L diesel engine codes: N16A1, N16A2, N16A3.
- Equivalent to OEM tools 07MAB-PY30100, 070AB-RJA0100. Kit includes camshaft locking pins and tensioner pins as required.
- EU Registered Design. Made in Sheffield. Use in accordance with OEM instructions.

<http://lasertools.co.uk/product/8130>

